

Smart Toilet Cubicle
Access Control System



Introduction

The smart toilet cubicle system provided by **ACX** is a cutting-edge solution that elevates the washroom experience by integrating features such as touchless controls, real-time occupancy tracking, and quick response for safety.

Highlights



Intelligent Occupancy Monitoring

The Status LED and Handwave Door Sensor work together to provide real-time visibility on the cubicle's availability, ensuring users can quickly identify vacant stalls and minimize wait times.

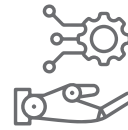

Automated Access and Control

The Arm-Shaped Electric Motorized Lock and the Thumbturn Electric Motorized Lock enable effortless, **touchless** entry and exit, promoting accessibility for all users.



Safety and Quick Response

The **ACX** Human Motion Detection Sensor and 2-in-1 Handwave and Panic Button detects the presence of users and enables users to alert staff in case of an emergency, ensuring safety and quick response.



Centralized Management and Monitoring

The **ACX. 90** Software System: centralized control allows for efficient management, maintenance, and analytics, optimizing the overall performance and user.



Manufacturer-Backed Support

ACX provides authorized technicians to offer comprehensive technical support and maintenance within the Defects Liability Period, ensuring the long-term reliability and smooth operation of the smart toilet cubicle system.

Cubicle Major Components

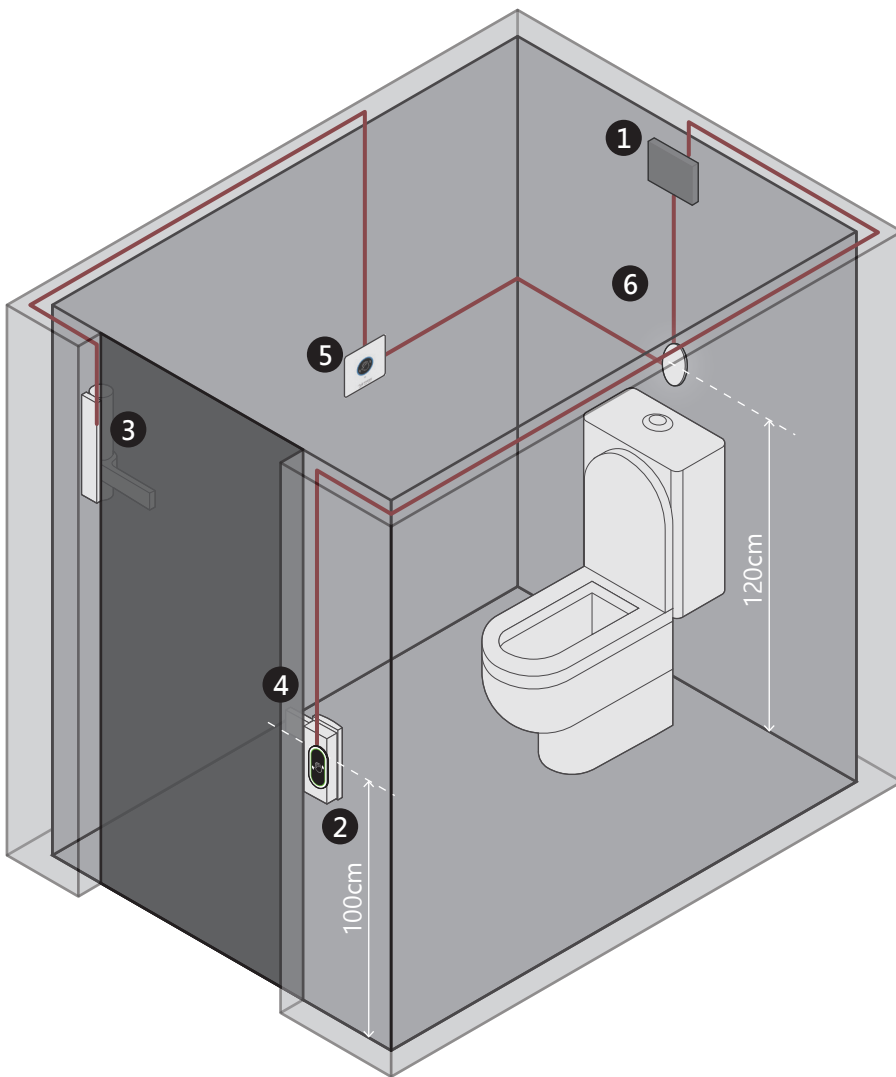

- 1 Cubicle Controller
- 2 Touchless handwave Sensor
- 3 Arm-Shaped Electric Motorized Lock
- 4 Thumbturn Electric Motorized Lock
- 5 2-in-1 Handwave and Panic Buttons
- 6 Human Motion Detection Sensor

Product Details



Item No: ACX.90

Item Description: ACX Software System

- Provides the core software and control system for the smart toilet cubicle solution
- Manages the various hardware components and their integration
- Enables centralized monitoring, control, and automation of the cubicle functions



Item No: 8600

Item Description: Cubicle Master Controller

- Enables centralized control and communication between the software system and hardware devices



Item No: 8601

Item Description: Cubicle Controller (inside the cubicle)

- Control and monitor the smart cubicle access control accessories



Item No: 8602

Item Description: Touchless handwave Sensor

- Detects the presence of users approaching the cubicle door
- Triggers appropriate actions, such as unlocking the door
- Visually indicates the occupancy status of the toilet cubicle (e.g., available, occupied, problems, etc.)
- Helps users quickly identify the availability of the cubicle



Item No: 8604

Item Description: Arm-Shaped Electric Motorized Lock

- Automatically **opens and closes** the toilet cubicle door
- Ensures accessibility and ease of use for users, especially those with mobility challenges



Item No: 8605

Item Description: Thumbturn Electric Motorized Lock

- Provides an **electronic locking** mechanism for the cubicle door
- Automatically **locks and unlocks** the toilet cubicle door
- Includes a manual override feature for emergency situations or power outages



Item No: 8606

Item Description: 2-in-1 Handwave and Panic Buttons

- Allows users inside the cubicle to easily release the door and exit the cubicle
- Includes a safety bell feature to alert nearby staff or security personnel if assistance is needed

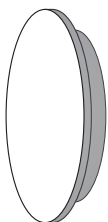

Item No: 8607

Item Description: Human Motion Detection Sensor

- Detects the presence and movement of users inside the cubicle
- Triggers actions based on object movement.

System Diagram

The provided system diagram illustrates the various hardware components and their interconnectivity within the smart toilet cubicle system.

Smart Cubicle Access Control System Diagram

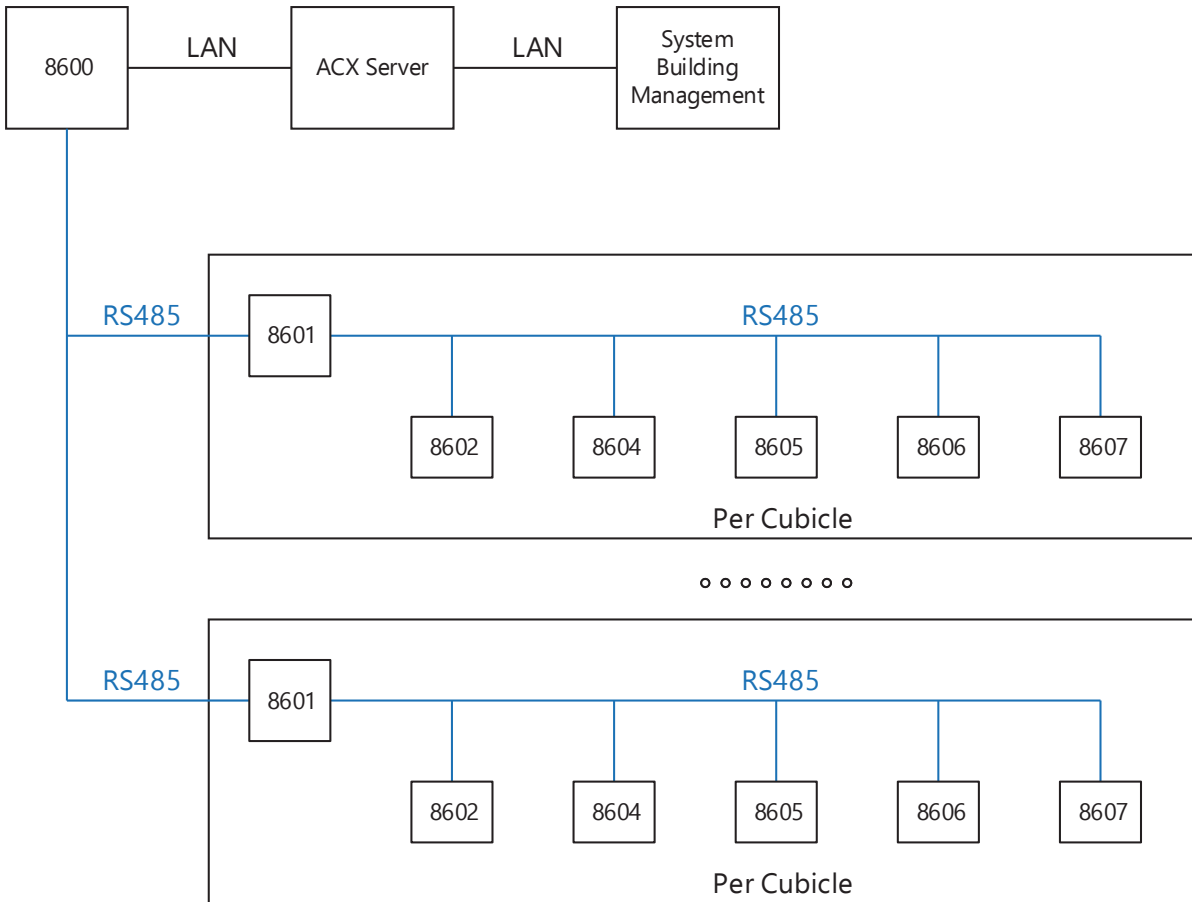

Legend

8600	Cubicle Master Controller	8605	Thumbturn Electric Motorized Lock (inside the cubicle)
8601	Cubicle Controller (inside the cubicle)	8606	2-in-1 Handwave and Panic Buttons (inside the cubicle)
8602	Touchless handwave Sensor (outside the cubicle)	8607	Human Motion Detection Sensor (inside the cubicle)
8604	Arm-Shaped Electric Motorized Lock (inside the cubicle)		

Scenarios

Lorem ipsum

The use case or operation flow outlines the expected functionality and user interactions with the smart toilet cubicle system.

LED Indicator Status

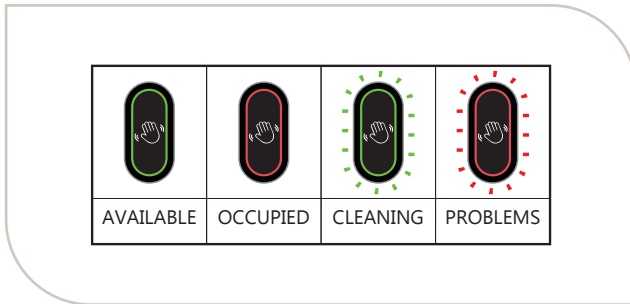

Arm-Shaped Electric Motorized Lock Motion

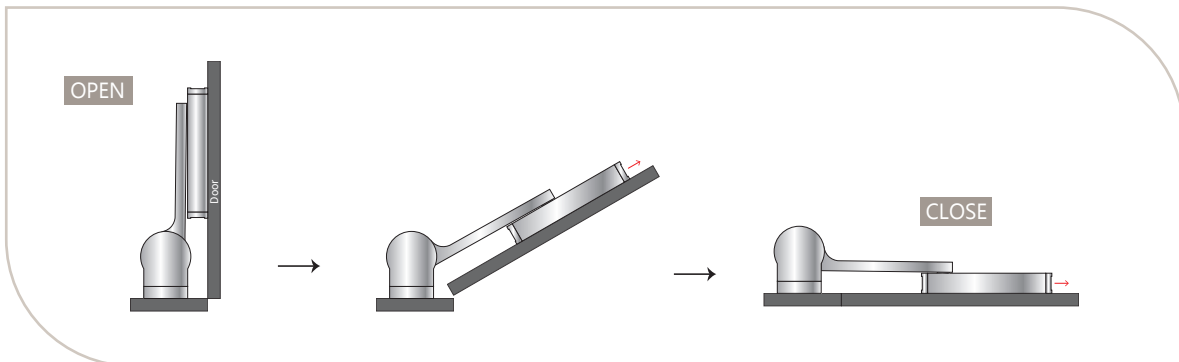

Thumbturn Electric Motorized Lock Motion

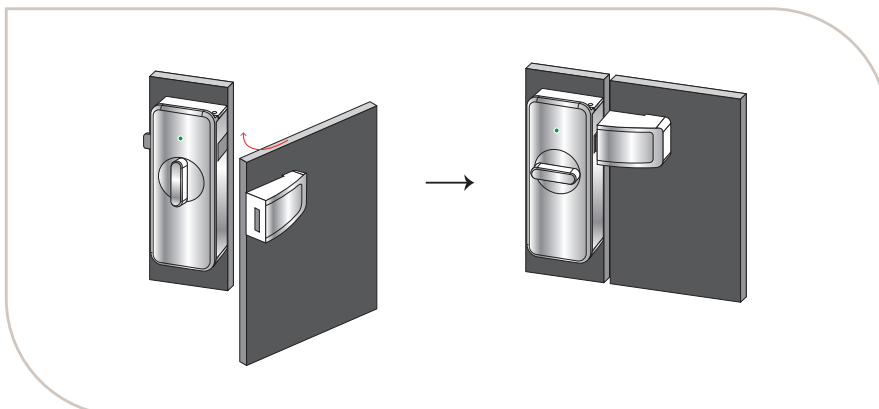

SCENARIOS

Normal Operation

Scenario 1 – Normal Opening & Closing (Automation)

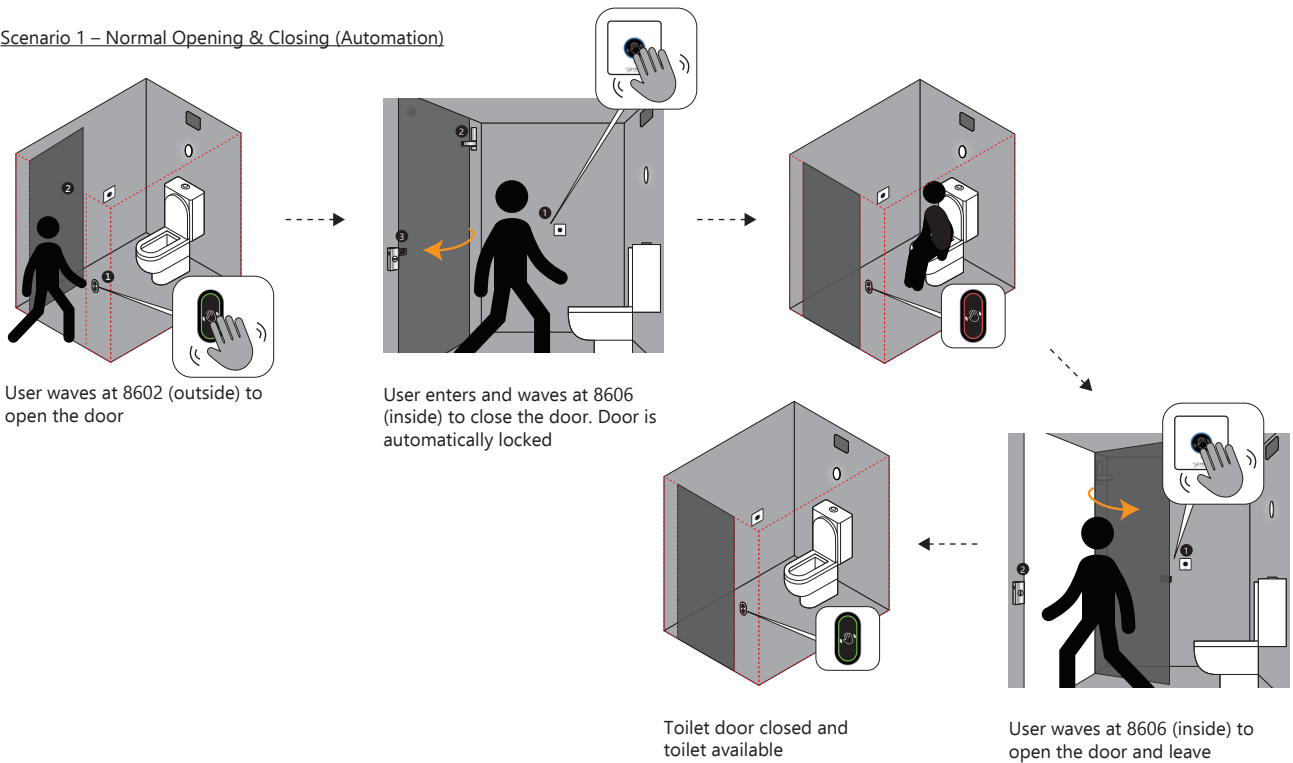

Scenario 2 – Janitor Mode



SCENARIOS

Accident happened

Scenario 1 – Close Door Manually (Manual operation)

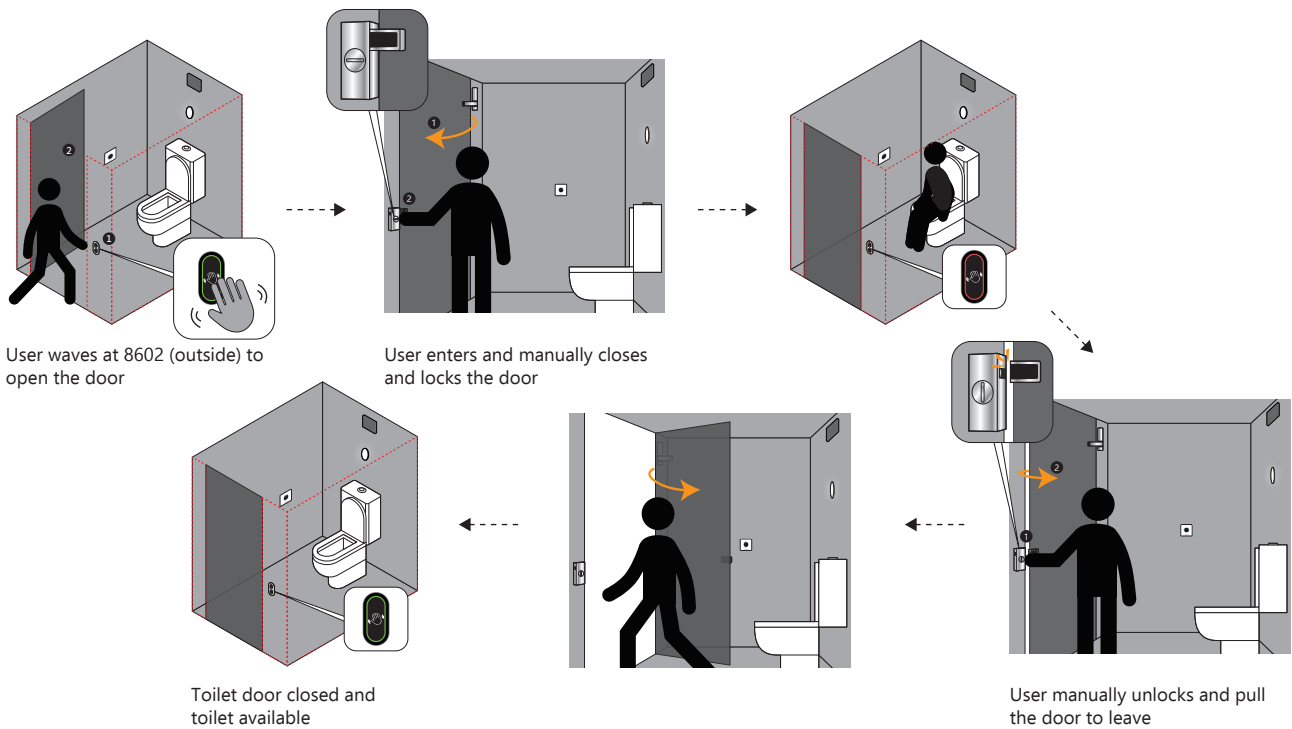

Scenario 2 – Door Remains Closed*

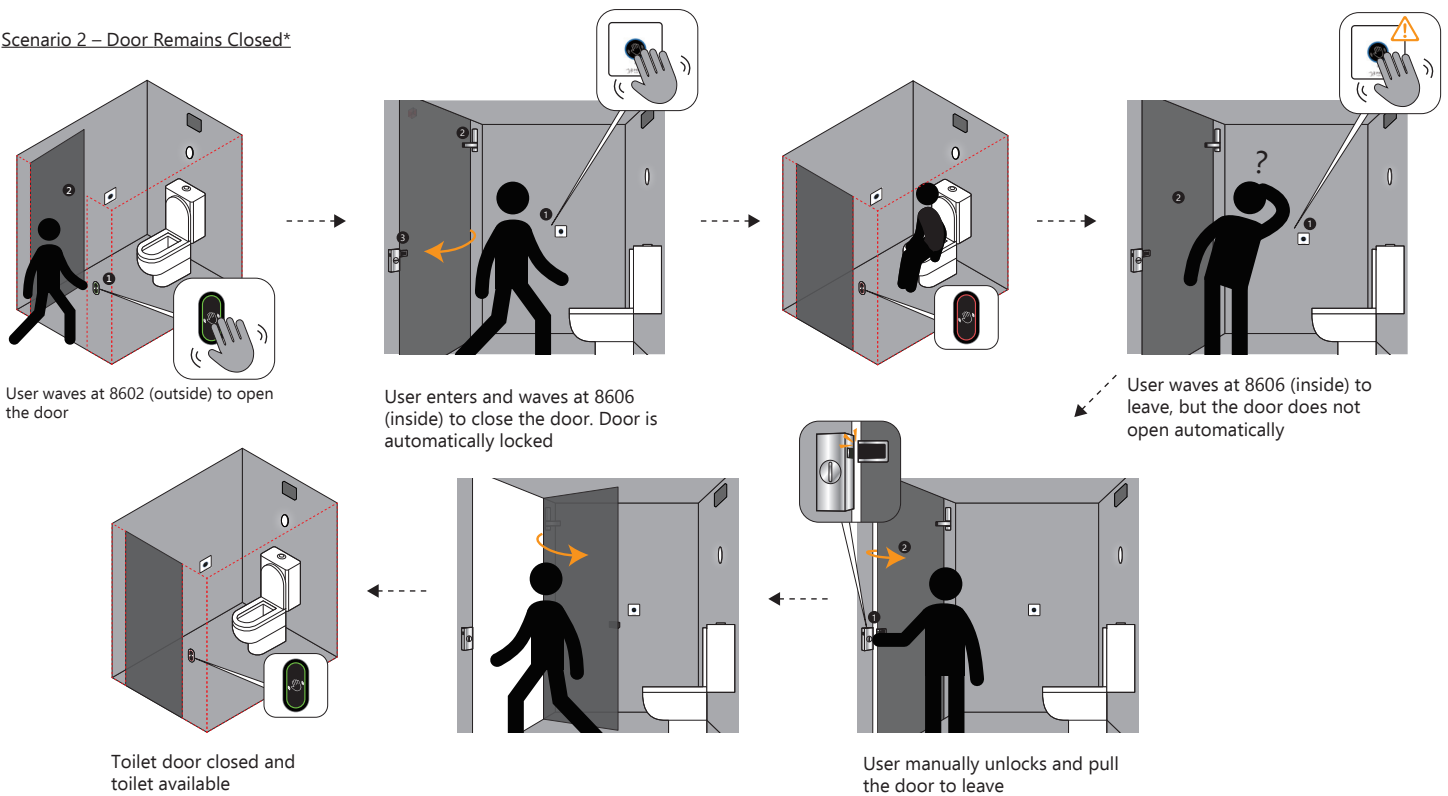

*In case of power outage, malfunction of any electronic component, or any situation causing the door to remain closed

SCENARIOS

Accident happened

Scenario 3 – Accident/Collapse

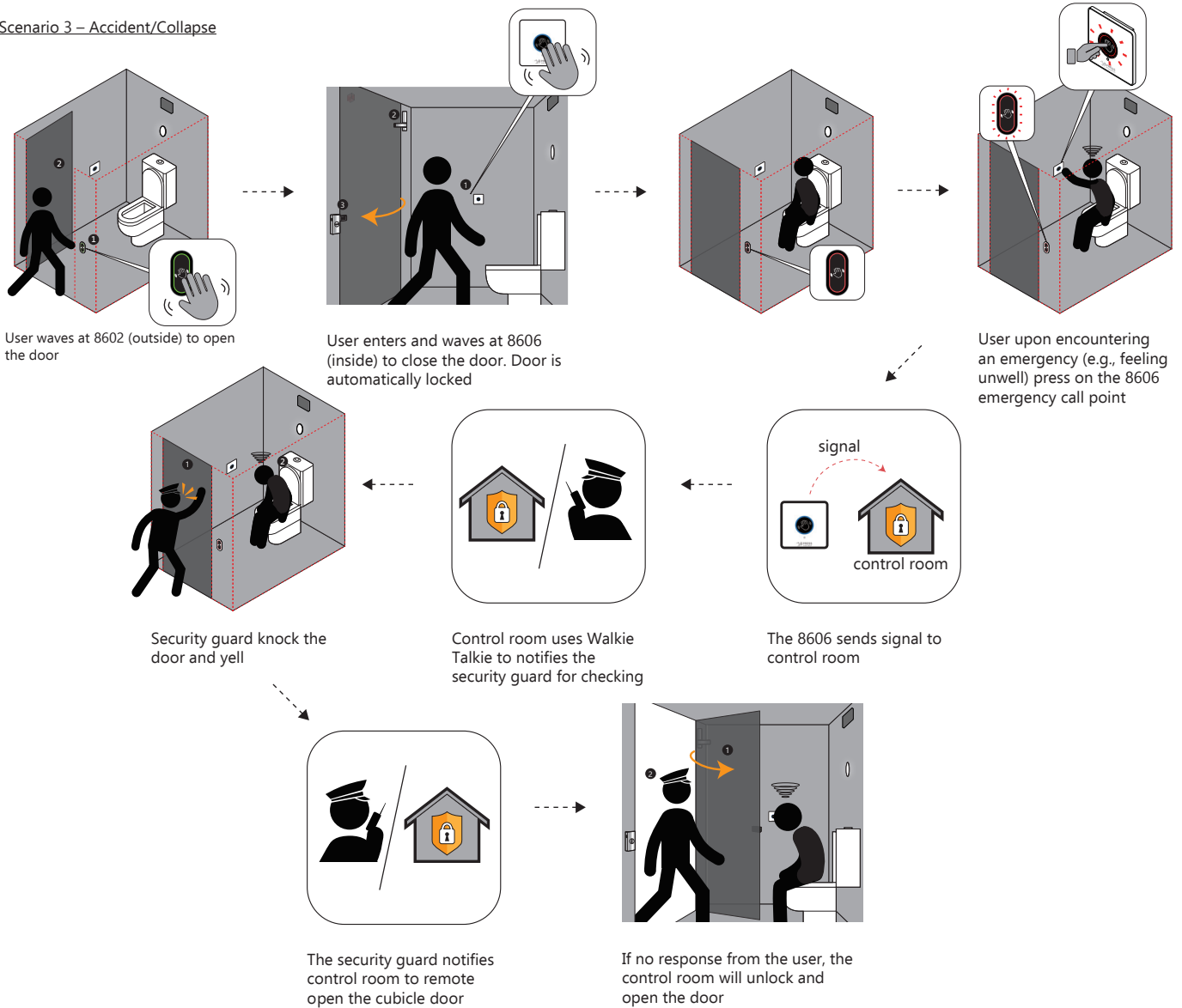

SCENARIOS

Accident happened

Scenario 4 – Accident/Collapse



User waves at 8602 (outside) to open the door

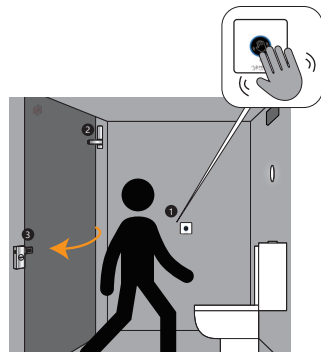

User enters and waves at 8606 (inside) to close the door. Door is automatically locked

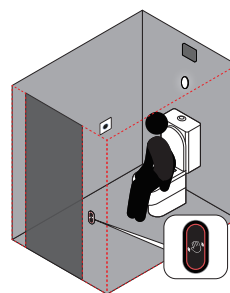

User unconscious. The 8607 human detection sensor detects no object movement for 10s

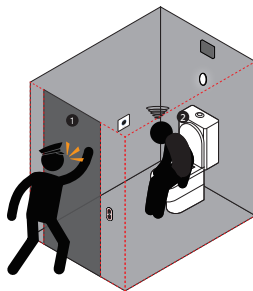

Security guard knock the door and yell



Control room uses Walkie Talkie to notifies the security guard for checking

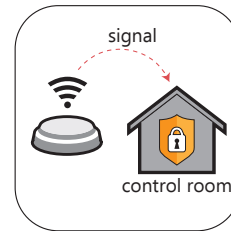

The 8607 sends signal to control room



The security guard notifies control room to remote open the cubicle door

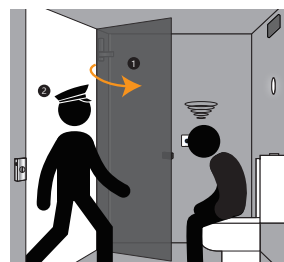

If no response from the user, the control room will unlock and open the door

Maintenance Manual

1. No attempt should be made to remove any of the brackets, fittings, doors or panels without correct replacement as this could weaken the unit and invalidate any warranty or guarantees.

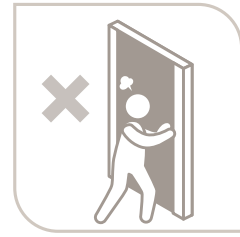

2. Clean laminate surfaces regularly when in use. Polishes are unnecessary.



3. For general cleaning do not use abrasives or scouring powder, steel wool.

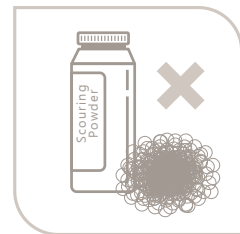

4. Do not use polishes, wax, furniture cleaners or bleaches.

5. Do not use cleaning agents which contain strong acids salts e.g., decalcifiers with formic acid or sulphuric acid bases, drain cleanser, hydrochloric acid, silver cleaners, oven cleansers.



6. Please use MILD ACID/ALKALINE for cleaning at toilet area. After that, it is very important to clean up the stainless-steel hardware with a damp cloth as to keep no long contact of stainless steel with corrosion agent.



7. For the tiny dots on the aluminum laminate is due to the oxidation of aluminum in humidity area and also by vapor acid. It is also advised to use a damp cloth for general cleaning and after MILD ACID/ALKALINE for cleaning at toilet area.



8600 Master Smart Toilet Controller, with its ability to monitor and control multiple cubicle controllers, provides a robust solution for access management in cubicle facilities. Its remote management capabilities and real-time monitoring features make it a valuable tool for enhancing security and operational efficiency.



BENEFITS

Operational Efficiency: The ACX. 8600 streamlines access management, allowing for smoother operations and reducing the time spent on administrative tasks related to access control.

- **Cost-Effective:** Centralizing management can reduce the costs associated with maintaining multiple systems, leading to lower staffing requirements for security management.
- **Compliance and Reporting:** The ability to generate reports on access activity aids organizations in maintaining compliance with industry regulations and internal policies.
- **Increased User Satisfaction:** With improved access control, users experience fewer disruptions, leading to higher satisfaction and productivity in the workplace.

KEY FEATURES

1. **Multi-Controller Monitoring:** The ACX.8600 can oversee multiple cubicle controllers, allowing for centralized management of access points. This is particularly beneficial in extensive facilities where numerous access points must be monitored.
2. **Remote Management:** With its remote management capabilities, administrators can control and monitor access from anywhere, enhancing operational flexibility. This is particularly useful for facilities with multiple locations or organizations requiring off-site management.
3. **Real-Time Monitoring:** The system provides real-time data on access events, which can be crucial for security audits and incident response. Administrators can quickly assess access patterns and respond to potential security breaches.
4. **Scalability:** The system is designed to grow with your needs. As your facility expands or your access control requirements change, the ACX.8600 can adapt without requiring a complete overhaul of the existing system.

SPECIFICATION

8600 Master Smart Toilet Controller	
Power	12V, 3A DC Input
Connection	Connects to the ACX.8601 controller by RS485. The maximum cable length is 1,200 meters. Connects to the ACX Server by TCP. The maximum cable length is 100 meters.
Cable	RS485 cable : Shield twist pair cable. LAN Cable : CAT6.
Dimension	86mm(L) x 54mm(W) x 12mm(H) without connectors 110mm(L) x 54mm(W) x 20mm(H) with connectors

8601 is a secondary controller in the system, facilitating communication between the cubicle master controller (ACX.8600) and the connected field devices. The field devices include the ACX.8602 handwave sensor, ACX.8604 Arm-Shaped Electric motorized lock, ACX.8605 Thumbturn Electric motorized lock (Manual Override), ACX.8606 Handwave and Panic button, and the ACX. 8607 Human Motion Detection Sensor.



BENEFITS

- **Efficient Communication:** By managing the communication load, the ACX.8601 helps maintain efficient communication pathways, critical in real-time systems where timely data exchange is essential.
- **Centralized Control:** It allows the ACX.8600 to focus on higher-level functions, such as overseeing operations and making decisions based on the processed data from multiple secondary controllers like the ACX.8601.
- **Improved Performance:** By handling specific tasks, the ACX. 8601 can improve the system's overall performance, leading to faster response times and reduced communication latency.

KEY FEATURES

1. **Communication Bridge:** The ACX.8601 is an intermediary that translates and relays data between the master controller (ACX.8600) and field devices. This ensures seamless data flow and command execution.
2. **Data Processing:** It may perform initial data processing from field devices before sending it to the master controller. This can include filtering, aggregating, or formatting data to optimize communication.
3. **Device Management:** The controller helps manage the connected field devices, including monitoring their status, collecting diagnostics, and facilitating updates or reconfigurations.
4. **Redundancy and Reliability:** By offloading some communication tasks from the master controller, the ACX.8601 can enhance system redundancy and reliability, ensuring that field devices continue to operate effectively even if there's an issue with the master controller.
5. **Enhanced Scalability:** Integrating a secondary controller allows for easier system expansion. Additional field devices can be added without overwhelming the master controller.

SPECIFICATION

8601 Cubicle Controller	
Power	12V, 3A DC Input
Connection	Connects to the 8601 controller and the field devices by RS485. The maximum cable length is 1,200 meters.
Cable	RS485 cable : Shield twist pair cable.
Dimension	86mm(L) x 54mm(W) x 12mm(H) without connectors 110mm(L) x 54mm(W) x 20mm(H) with connectors
Field Devices	<ol style="list-style-type: none">1. ACX.8602 Handwave Sensor<ul style="list-style-type: none">• A sensor that allows users to interact with the system without physical contact, possibly for activating features like unlocking doors or turning on lights.2. ACX.8604 Arm Shape Electric Motorized Lock<ul style="list-style-type: none">• An electric lock that likely employs a motorized mechanism to secure entry points, activated by the cubicle controllers.3. ACX.8605 Thumbturn Electric Motorized Lock (Manual Override)<ul style="list-style-type: none">• A motorized lock that can be manually operated via a thumbturn, providing a backup method of unlocking in case of power failure or system issues.4. ACX.8606 Handwave and Panic Button<ul style="list-style-type: none">• A combined device that allows users to wave their hands to activate specific functions and includes a panic button for emergencies.5. ACX.8607 Human Motion Detection Sensor<ul style="list-style-type: none">• A sensor designed to detect human presence, which can be used for security or automation purposes, such as activating lights or alarms when someone enters an area.

8602 Touchless Handwave Sensor is a convenient and innovative solution for improving accessibility and hygiene in shared spaces like cubicles. Here's a breakdown of its features and benefits, as well as potential applications:



BENEFITS

- **Enhanced Hygiene:** Minimizing contact with surfaces helps maintain a cleaner environment, especially in communal areas.
- **Increased Accessibility:** Ideal for individuals with mobility issues or those carrying items, as it eliminates the need to touch the door.
- **Improved Flow of Movement:** Users can enter and exit cubicles more efficiently, reducing wait times and enhancing workflow in busy office settings.
- **Modern Aesthetic:** The sleek design can complement modern office decor, adding to the workspace's overall aesthetic appeal.

KEY FEATURES

1. **Touchless Operation:** The sensor allows users to open the cubicle door without physical contact, promoting hygiene by reducing the spread of germs.
2. **Occupancy Status Indicator:** The sensor may incorporate visual indicators (such as LEDs) to show whether the cubicle is occupied or available, helping users make quick decisions.
3. **Easy Installation:** It is designed to be mounted on the door frame and can typically be installed with minimal disruption.
4. **User-Friendly Interface:** The handwave gesture is intuitive, ensuring users can easily operate the door without detailed instructions.
5. **Durability and Reliability:** Built to withstand frequent use, the sensor will likely be durable and reliable in a busy environment.

SPECIFICATION

8602 Touchless Handwave Sensor	
Power	12V, 100mA DC Input
Connection	Connects to the ACX.8601 controller by RS485. The maximum cable length is 1,200 meters.
Cable	RS485 cable : Shield twist pair cable.
Dimension	70mm(L) x 35mm(W) x 4mm(D)
Field Devices	<ul style="list-style-type: none">• Green - Cubicle is ready to use• Red - Cubicle is occupied• Flash Green - The Cubicle is under Cleaning• Flash RED - Problem in the Cubicle

DIMENSION

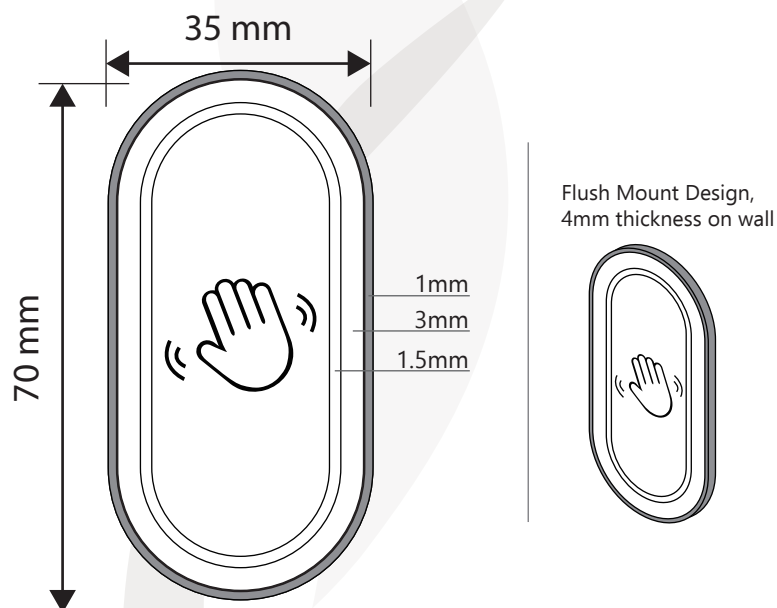

MANUAL OVERWRITE

1. Remove the label from the 8602 (outside)
2. Use a flathead screwdriver to manually twist and unlock the 8605 (inside).

Disassembly Process:

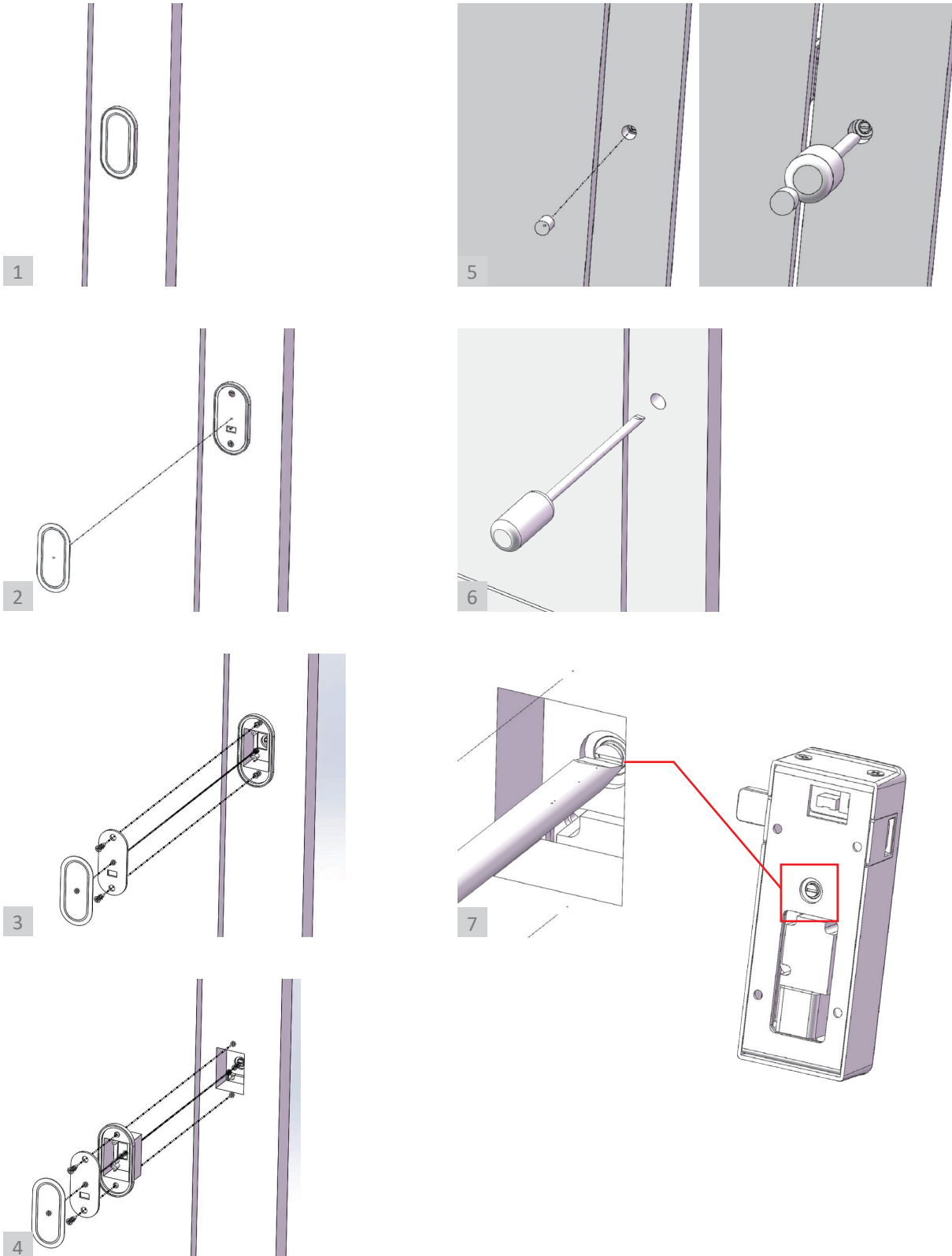

8604 Arm-Shaped Electric Motorized Lock combines innovative design with practical functionality, making it a compelling choice for various applications requiring secure, automated door control. Its ability to integrate with software solutions further enhances its versatility in modern smart environments.



BENEFITS

- **Enhanced Security:** Provides a reliable locking mechanism for cubicles.
- **User-Friendly:** Hands-free operation can improve user experience and convenience.
- **Customizable:** The SDK allows for tailored features to meet specific user needs or integrate with existing systems.
- **Safety:** The automatic backward motion feature ensures that the lock does not damage itself or surrounding objects.

KEY FEATURES

1. Design and Installation: Arm-Shaped Design: The locker is designed in an arm shape, likely allowing for a more effective engagement with the door mechanism.
2. Installation Location: It is installed on the door frame inside the cubicle, which helps maintain aesthetics and functionality without protruding into the cubicle space.
3. Metal Fixed Track: A sturdy metal fixed track is mounted on the cubicle door, which likely aids in the smooth operation of the locker. This could help in guiding the arm-shaped mechanism accurately.
4. Motorized Control: The locker can fully control the opening and closing of the cubicle door, providing a hands-free experience for users. This could be particularly beneficial in environments where hygiene is a concern, such as hospitals or laboratories.
5. Software Development Kit (SDK) Control: The motion of the lock set is controlled by an SDK, indicating that it can be integrated into larger systems or customized for specific applications. This allows for adaptability and seamless integration with other intelligent office solutions.
6. Automatic Backward Motion: The lock features an automatic backward motion when it encounters an object. This safety feature is essential to prevent damage to the lock, the door, or any object that might obstruct its movement, enhancing user safety and system reliability.

SPECIFICATION

8604 Arm-Shaped Electric Motorized Lock	
Power	12V, 2A DC Input
Connection	Connects to the ACX.8601 controller by RS485. The maximum cable length is 1,200 meters.
Cable	RS485 cable : Shield twist pair cable.
Dimension	Refer details below
Force	Power supply 12V, operating current 0.5A, stall current 1.5A, torque 100kg/cm, speed 5 rpm

DIMENSION

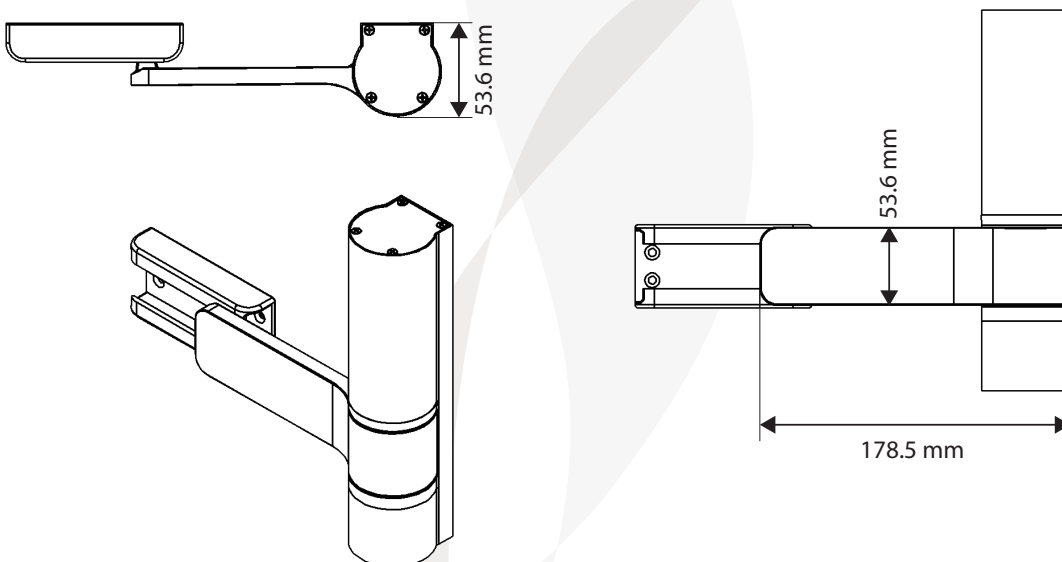

8605 Thumbturn Electric Motorized Lock combines convenience and security, making it a robust solution for modern access control needs in cubicle environments. Its manual override, status indication, and programmability via SDK make it adaptable to various applications, enhancing user experience and operational efficiency.



BENEFITS

- **Enhanced Security:** The electric motorized lock provides a higher level of security than traditional locks, reducing the risk of unauthorized access.
- **User-Friendly:** The thumb turn feature allows for easy manual operation, while the LED status indicator ensures users are always aware of the lock's state.
- **Integration Flexibility:** With SDK access, the lock can be integrated into larger security systems or customized applications, providing flexibility for different use cases.

KEY FEATURES

1. Thumbturn Mechanism:

- Allows users to manually lock or unlock the door using a thumbturn.
- Provides a backup mechanism in case of power failure or system malfunction.

2. Electric Motorized Operation:

- The lock can be operated electronically, allowing for remote access control.
- Suitable for integration into automated access systems.

3. LED Status Indicator:

- A built-in LED displays the lock status (locked or unlocked).
- Enhances user experience by providing clear visual feedback.

4. SDK Control:

- A Software Development Kit (SDK) can control the lock programmatically.
- Facilitates custom software integration, allowing for automation and remote management.
- Ideal for developers looking to create tailored access control solutions.

5. Installation:

- Designed to be installed within the cubicle's door frame, ensuring a discreet and secure fit.
- Compatible with various door types and frames.

SPECIFICATION

8605 Thumbturn Electric Motorized Lock

Power	12V, 300mA DC Input
Connection	Connects to the ACX.8601 controller by RS485. The maximum cable length is 1,200 meters.
Cable	RS485 cable : Shield twist pair cable.
Dimension	Refer details below
Cleaning Mode	People manually turn right and turn left within 5 seconds; the cubicle will be changed to cleaning mode. The LED of the ACX.8602 touchless handwave sensor will be changed to flashing GREEN.
Accident Mode	The LED of the ACX.8602 touchless handwave sensor will be changed to flashing RED.
Force	Power supply 12V, operating current 0.5A, stall current 1A, torque 8kg/cm, speed 31 rpm

DIMENSION

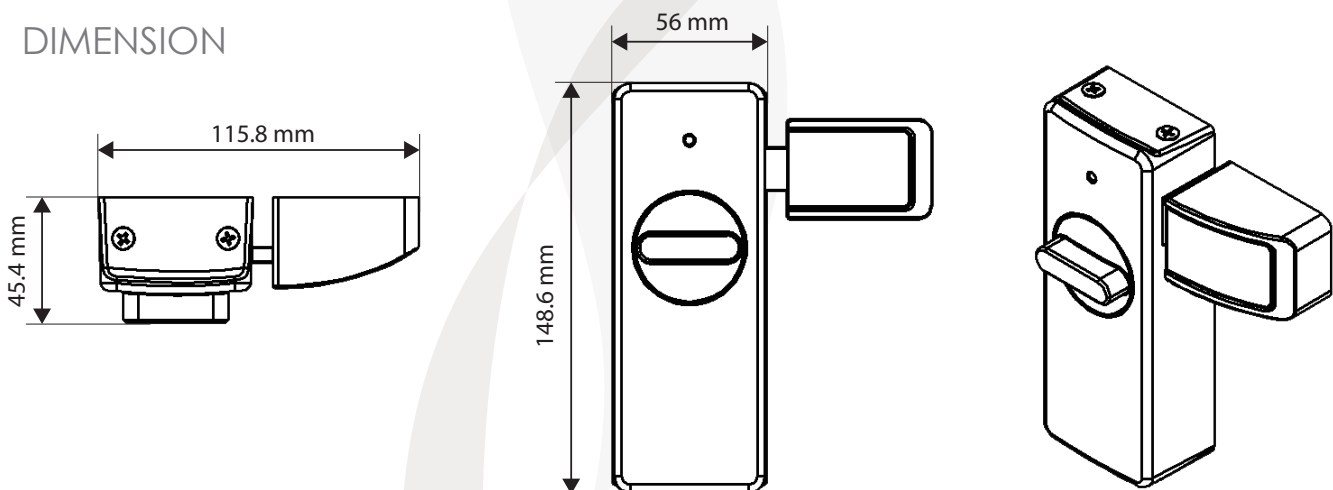

8606 is a 2-in-1 device that combines handwave and panic button. It is an innovative solution for modern cubicle setups, combining convenience with safety features to enhance user experience and security. This dual functionality makes it ideal for offices, public facilities, and any environment requiring efficient access and emergency response capabilities.



BENEFITS

- **Enhanced Safety:** Integrating a panic button improves user safety when quick alerting is crucial.
- **Convenience:** The handwave operation eliminates the need for physical contact, which is particularly beneficial in shared spaces.

KEY FEATURES

1. Handwave Control:

- Purpose: Provides a touchless method to open and close the cubicle door, promoting hygiene and ease of access.
- Operation: Users can wave their hands in front of the device to activate the door mechanism.

2. Panic Button:

- Purpose: Offers a quick and reliable way to alert the central control office in an emergency.
- Operation: Users can press the circular button located on the device to send an immediate help message.

SPECIFICATION

8606 2-in-1 Handwave and Panic Button	
Power	12V, 300mA DC Input
Connection	Connects to the ACX.8601 controller by RS485. The maximum cable length is 1,200 meters.
Cable	RS485 cable : Shield twist pair cable.
Dimension	86mm(L) x 86mm(W) x 4mm(D)
LED	<ul style="list-style-type: none">• Normal - BLUE• Trigger - GREEN• Panic Push - RED
Panic Button	Once the Panic Button is triggered, the Panic Button can be reset by a special tools.

DIMENSION

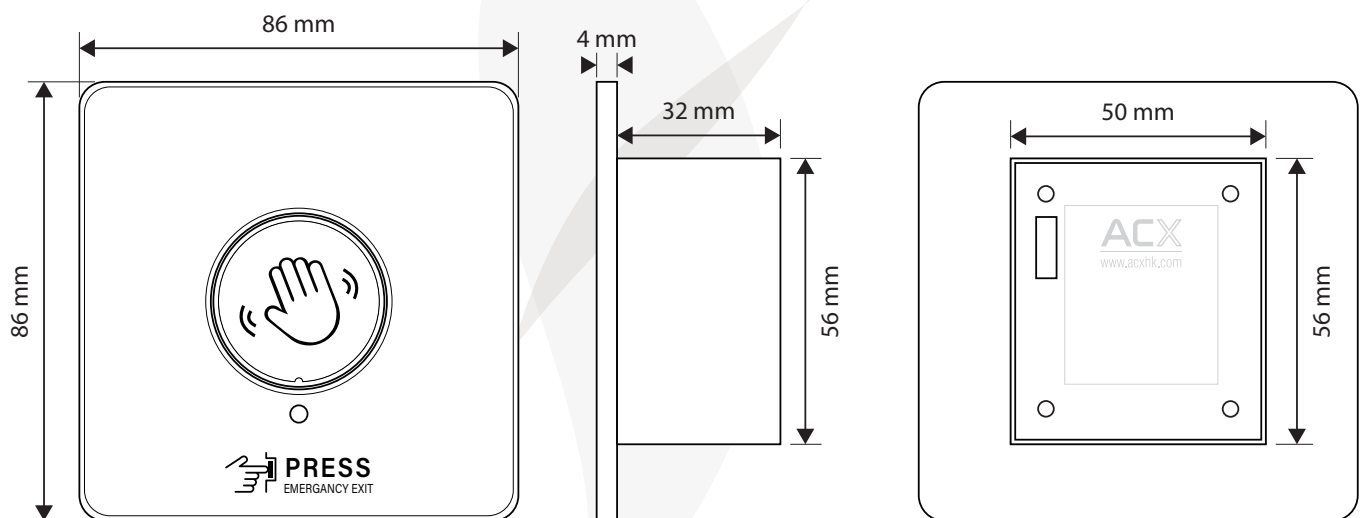

SCENARIOS

1. Hand wave for leave

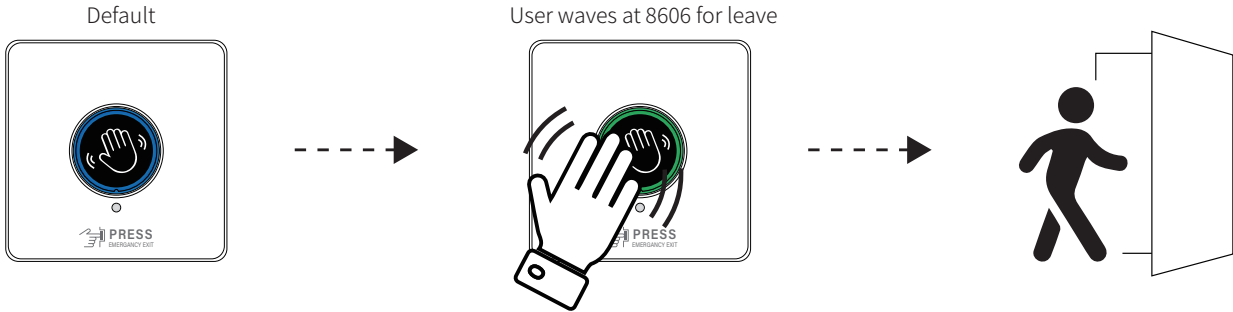

2. Press for emergency exit

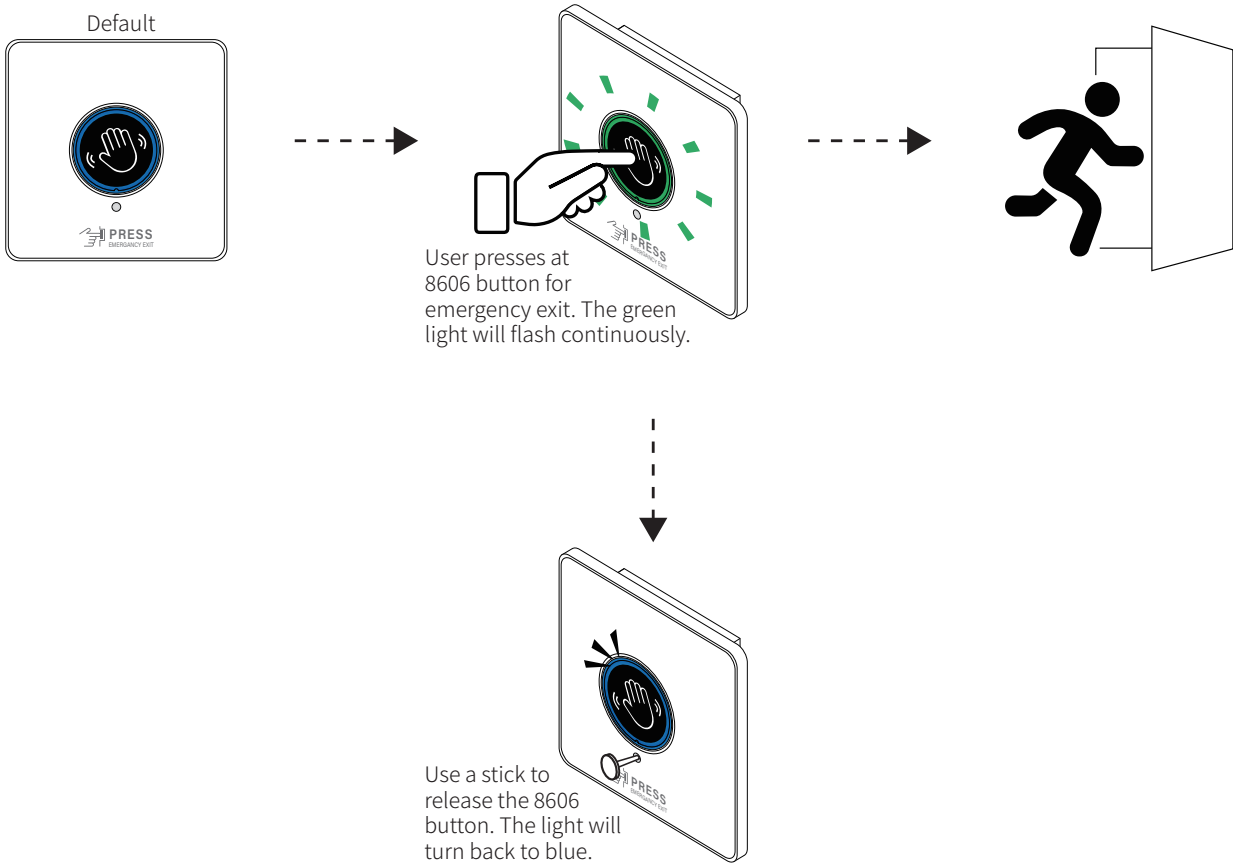

8607 Human Motion Detection Sensor is a significant tool for enhancing safety and security in various environments. Effectively monitoring motion and providing timely alerts is vital in emergency response protocols, ultimately helping protect individuals and improving overall safety standards.

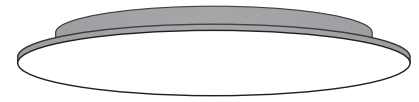

BENEFITS

- **Healthcare Facilities:** In hospitals or nursing homes, the sensor can monitor patients who are at risk of falling or losing consciousness, enabling staff to respond quickly.
- **Workplaces:** In environments where employees work alone or in isolated areas, the sensor can help ensure safety by notifying supervisors if someone becomes unresponsive.
- **Public Spaces:** The sensor can be used in areas like airports or shopping malls to enhance security and safety for visitors, particularly in high-traffic areas.

KEY FEATURES

1. **Sensitivity Configuration:** The sensor allows for adjustable sensitivity levels, enabling it to be customized based on the specific environment or requirements. This feature helps reduce false positives in busy areas or increase sensitivity in critical zones.
2. **Detection of Unconsciousness:** The primary function of the ACX.8607 is to detect when a user becomes motionless for a specified duration, which could indicate a loss of consciousness or fainting. This capability is crucial for ensuring prompt assistance in emergencies.
3. **Signal Transmission:** Once the sensor detects a lack of motion beyond the configured threshold, it triggers a signal to the cubicle controller. This immediate response helps in the rapid communication of potential emergencies.
4. **Alerting Systems:** The cubicle controller relays the alert to the ACX server, which can take further action. This might include:
 - Sending notifications to designated personnel or operational teams.
 - Integrating with building management systems (BMS) to ensure a coordinated response.
 - Activating alarms or visual indicators to draw attention to the situation.

SPECIFICATION

8607 Human Motion Detection Sensor	
Power	12V, 300mA DC Input
Connection	Connects to the ACX.8601 controller by RS485. The maximum cable length is 1,200 meters.
Cable	RS485 cable : Shield twist pair cable.
Dimension	Circle 86mm(L) x 86mm(W) x 4mm(D)
Color	White

ACX

www.acxhk.com